

Digital temperature controller

User guide



A106

Product description

The A106 model is a temperature controller specific for controlling freezing and deep-freezing counters and storage rooms with electric or hot gas defrosting management and fan control.

This model has waiting time parameters (delays) for device energization and relay operation.

Other functions present in the A106 are: eco mode, thermometer mode, support for WEB communication via RS-485 for the Arcsys and Arcsys Cloud monitoring system, temperature records, alarm and standby mode.

The A106 has 6 keys with shortcuts to simplify the use of the temperature controller.

Specifications

Power supply voltage	(110 or 220) Vac
Rated power	2 VA
Relay outputs	Compressor (17 A / 250 Vac) Defrosting (10 A / 250 Vac) Fan (5 A / 250 Vac) Note: The sum of the relay currents must not exceed 17 A
Digital input	Door sensor
Measurement range	(-50 to +100) °C
Resolution	0,1 °C (within the range: -50°C to +100°C)
Operating conditions	(0 to 40) °C and (10 to 80) % RH (noncondensing)
Panel cutout	(70 x 29) mm (± 5%)
Protection index	IP 65 (front panel)
NTC Sensor (IP68)	Ø6 mm / L=15 mm (sensor) Standard length 1,5 m (wiring)

Applications





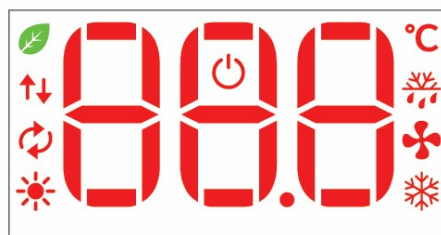

- Freezing and deep-freezing temperatures
- Counters and cold rooms



Display



A106 Display

Display icons

LED	Description
	- Off during normal operation. - On if the controller is in thermometer or Standby modes.
	- On when the device is in eco mode.
	- On when the programming key is being used. - Flashing if communicating with ArcSys (remote monitoring system).
	- Off during normal operation - On when the door is opened during test mode (Cd = 77).
	- Not used on this model.
	- On when the information shown on the display is a temperature in degrees Celsius.

	- On during the defrost cycle. - Flashing when the controller is waiting for the delay (defined by the parameter r9) to time out.
	- On when the fan is running. - Flashing when the controller is waiting for the delay (defined by the parameter F0) to time out.
	- On during the refrigeration cycle - Flashing during the device energization delay defined by r9, C1 or C2 parameters.



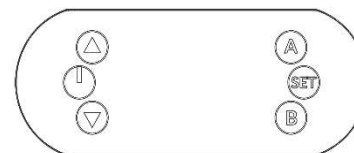

User interface

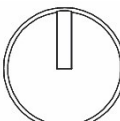

A106 interface

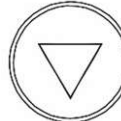
Key functions

Key	Description
	- Used to increment values. - If pushed together with the down key for 4 seconds, the controller will enter or exit the parameters setting list. - If pushed quickly, the defrosting temperature will be shown.
	- Used according to the value in the FP parameter. NOTE: Use this function responsibly. In certain applications, disconnecting loads may spoil/damage the products.

	- Used to decrement values. - If pushed together with the up key for 4 seconds, the controller will enter or exit the parameters setting list. - If pushed quickly, the display will show the current operation cycle. - If pushed for more than 4 seconds, it will skip to the next refrigeration cycle
	- If pushed for 2 seconds, the controller will enter/exit eco mode (If parameter FE = YES). - If pushed in the parameters setting list, with Cd = 97, it will reset the parameters to factory default values. - If during test mode (Cd = 77), it switches on the defrosting relay.
	- Used to show the setpoint on the initial screen and the values in the parameters setting list. - Along with the up and down keys, is used to adjust values of the setpoint and other parameters. - If during test mode (Cd = 77), it switches on the fan relay.
	- If pushed, the display will show the highest and lowest temperature values (tH and tL). If pushed again, it will re-define the temperature historical data. - If pushed in the parameters setting list, the firmware version will be displayed. - If during test mode (Cd = 77), switches on the compressor relay.

Dimensions

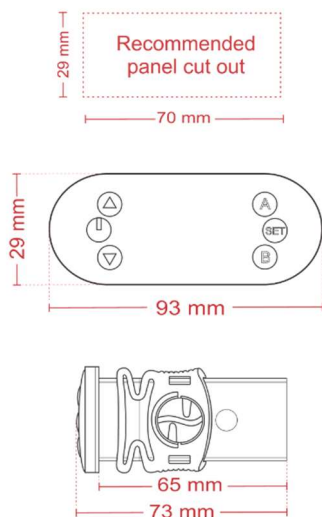

Fixing

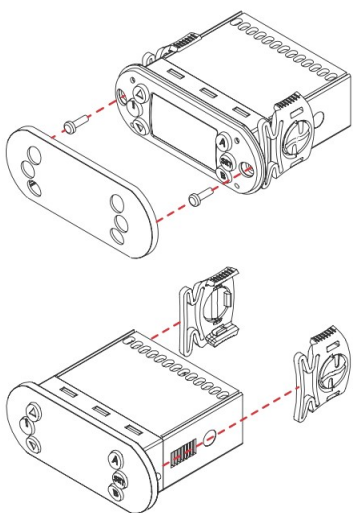

Fixing methods

NOTE: When making the cut, take into account the thickness of the paint/varnish that will be used.

Recommendations and warnings

If the controller has to be removed, detach the two side clips and pull the controller out. In case the fixing method chosen was by screws, remove the front display protection, remove the screws and pull the controller out.

It is recommended that the handling and installation of the equipment are carried out by

qualified personnel. Connections must be done with suitable connectors for better fixing to the terminals. Before energizing the device, make sure all the connections are correct, otherwise, irreparable damage may be inflicted. Never subject the system elements to a temperature outside the operating range (0 to 40 °C for the controller and -50 to 100 °C for the NTC sensors), as this could also cause irreparable damage. It is recommended to check the tightness of the terminal screws and condition of the wires every 6 months.

220 V connection

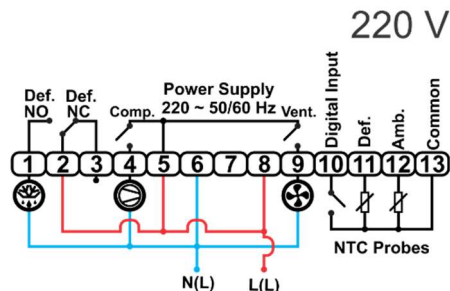

Step-by-step installation at 220 V:

- 1) Power supply: Terminals 6 and 8;
- 2) Jumper from terminal 8 to terminal 5;
- 3) Jumper from terminal 8 to terminal 2;
- 4) Compressor: Terminals 4 and 6;
- 5) Defrosting load: Terminals 1 and 6;
- 6) Cooling Fan: Terminals 9 and 6;
- 7) Ambient sensor: Terminals 12 and 13;
- 8) Evaporator sensor (Defrost): Terminals 11 and 13.

110 V connection

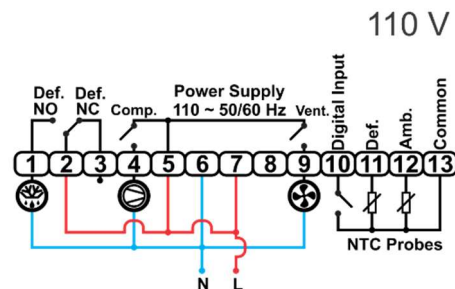

Step-by-step installation at 110 V:

- 1) Power supply: Terminals 6 and 7;
- 2) Jumper from terminal 7 to terminal 5;
- 3) Jumper from terminal 7 to terminal 2;
- 4) Compressor: Terminals 4 and 6;
- 5) Defrosting load: Terminals 1 and 6;
- 6) Cooling Fan: Terminals 9 and 6;
- 7) Ambient sensor: Terminals 12 and 13;
- 8) Evaporator sensor (Defrost): Terminals 11 and 13.

Parameters table

Parameter	Values	Default value
Cd Access code	0 to 999	0
Temperature control		
SP Setpoint	(r1 to r2) °C	0
SE Eco mode Setpoint	(r1 to r2) °C	2
r0 Differential (Hysteresis)	(0.1 to +20.0) °C	3.0
r1 Setpoint lower limit	-50 °C to SP	-50
r2 Setpoint upper limit	SP to +100 °C	100
r9 Delay for device starting	(0 to 20) min	1
Refrigeration		
C1 Delay after relay switching on	(0 to 20) min	0
C2 Delay after relay switching off	(0 to 20) min	2
C3 Percentage of relay operation in case of E1 error	(0 to 100) %	50
Defrosting		
d0 Defrosting method	EL or GA	EL
d1 Interval between defrost cycles	(1 to 999) hours	6
d2 Defrost duration time	(oFF, 1 to 999) min	20
d3 Temperature to end defrosting cycle	(-50 to +100) °C	2.0
d4 Defrosting at system start	YES or no	no
d6 Display locked during defrosting	YES, no, (1 to 99) min	YES
d7 Draining time	(0 to 20) min	2
d8 Defrost temperature control	YES or no	no
Cooling fan		
F0 Fan delay after draining	(0 to 15) min	3
F1 Evaporator temperature to turn off the fans	(-50 to +100) °C	30
F2 Fan temperature differential (Hysteresis)	(0.1 to +20.0) °C	2.0
F3 Cooling fan always on during refrigeration cycle (*F1)	YES or no	YES
F4 Cooling fan always on during electric defrosting	YES or no	no
Eco mode and door sensor		
P0 Door open time to turn off the fan	Off or (1 to 999) sec	5
P3 Door sensor operating mode	nA or nF ¹	nA
P4 Door closed time to enter eco mode	(0 to 999) min	30
P5 Door closed time to exit eco mode	(0 to 999) hours	0
Full mode		
The parameters below appear only if Cd = 38		
Key control		
FE Enable eco mode function	YES or no	no
FP Power key function	0,1 or 2	0
bt Block of settings changes 10 s after the last use of the keyboard	oFF, 1 or 2	oFF
Arcsys		
Ed Network address ²	0 to 32	6
bU Block settings changes via WEB (ArcSys and Cloud)	YES or no	no
Temperature alarm		
A0 Temperature alarm differential (Hysteresis)	(0.1 to 20.0) °C	3.0
A1 Minimum temperature alarm	(-50 to A2) °C	-50
A2 Maximum temperature alarm	(A1 to 100) °C	100
A3 Start-up alarm delay	(0 to 999) min	99
A4 WEB notification frequency (ArcSys and Cloud)	Every (0 to 240) min	0
Other adjustments		
FL Digital temperature filter	1 to 40	3
r4 Refrigeration sensor calibration (offset)	(oFF, -15.0 to +15.00) °C	0.0
d9 Defrosting sensor calibration (offset)	(oFF, -15.0 to +15.00) °C	0.0
tL Lowest temperature (historical minimum temperature) ³	(-50 to 100) °C	-
tH Highest temperature (historical maximum temperature) ³	(-50 to 100) °C	-
Notes		
¹ "nA" stands for "normally opened" and "nF" for "normally closed"		
² Visible and adjustable only on the controller and programming key, on Arcsys it will be only visible (not adjustable)		
³ View only		

¹ "nA" stands for "normally opened" and "nF" for "normally closed"

² Visible and adjustable only on the controller and programming key, on Arcsys it will be only visible (not adjustable)

³ View only

Parameters description

Cd – Access code: the parameters must be unlocked so they can be changed. To unlock them, enter the value **28** to **Cd** for the simplified parameterization mode or **38** for the full mode. If it is not done, the parameter values can only be viewed, but not changed. This parameter prevents unauthorized people from changing the programmed values.

SP – Setpoint: temperature value the user wants to obtain with the system.

SE – Eco mode Setpoint: temperature value the user wants to obtain with the system when the eco mode is on.

r0 – Differential (Hysteresis): The value of this parameter controls the operation of the relay, that is, it defines the temperature difference at which the relay will turn on/off. For example, if the device is in refrigeration mode and it is configured with setpoint = **5 °C** and **r0 = 2 °C**, the relay remains activated until the temperature reaches **5 °C**, then, it turns off. It only turns on again when the temperature reaches **7 °C (5 °C + 2 °C)**.

r1 – Setpoint lower limit: defines the lowest temperature value that the user can assign to the Setpoint and Eco mode Setpoint. Prevents a value below the recommended temperature limit from being applied to the system.

r2 – Setpoint upper limit: defines the highest temperature value that the user can assign to the Setpoint and Eco mode Setpoint. Prevents a value above the recommended temperature limit from being applied to the system.

r9 – Delay for device starting: defines a period after energizing the device in which all relays remain off. During this time, the device will only indicate the temperature value. This parameter protects the compressor from constant starts in case of power surges (consecutive power outages)

C1 – Delay after relay switching on: after activating the relay, it will remain on regardless of the temperature, for the period defined in **C1**. This parameter prevents voltage spikes in the power line.

C2 – Delay after relay switching off: after turning off the relay, regardless of the temperature, it will remain off for the period defined in **C2**.

C3 – Percentage of relay operation in case of “E1” error: if a problem occurs with the sensor (error E1), the relay will be activated cyclically and this parameter defines the percentage of 10 minutes the relay will remain on. For example, 50% of 10 minutes is 5 minutes.

d0 – Type of defrosting method: in this parameter, the user must enter which defrosting element will be used,

whether it will be an electrical resistance (EL) or by hot gas (GA). If it is chosen the electric defrost method, the refrigeration relay is turned off whenever the defrost relay is activated. With the hot gas defrosting method, the refrigeration relay is kept on whenever the defrost relay is activated.

d1 – Interval between defrost cycles: determines the time interval between the end of one defrost cycle and the beginning of the next one.

d2 – Defrost duration time: determines the duration of the defrosting cycle, that is, how much time the compressor will be off during one defrosting cycle.

d3 – Temperature to end defrosting cycle: determines the evaporator temperature to trigger the end of the defrosting cycle, that is, the maximum temperature at which defrost will turn off regardless of the time set in **d2**.

d4 – Defrosting at system start: allows you to defrost as soon as the device is turned on. This can be useful in applications with frequent power outages, as the controller resets time counts after shutdowns. It is often preferable to defrost at startup to prevent ice formation from happening due to a power outage.

d6 – Display locked during defrosting: allows locking, on the display, the temperature indicated at the beginning of defrosting to prevent any possible increase in temperature from being shown. After the fan delay cycle (**F0**), the temperature indication is unlocked. This parameter can be configured in the following ways:

- **no** – Display does not lock during defrosting;
- **YES** – Display locks during defrosting;
- **1 a 99 min** – the display locks for the defined time.

Important to notice that this time may exceed the total defrosting time. For example: if the defrost duration = 30 min and **d6 = 60 min**, the display will remain locked during the 30 min defrost + 30 min refrigeration cycle. The display will automatically unlock if the system temperature drops below the locking temperature (when the defrosting cycle started).

d7 – Draining time: defines the duration of the drain cycle, when the refrigeration will remain off to drain the water accumulated during defrosting.

d8 – Defrost temperature control: If set to **YES**, the defrost will end by time and, during this period (parameter **d2**), the defrost sensor temperature will be controlled according to the value in **d3** with a fixed hysteresis of 3 °C. If set to **no**, the end of defrosting will be by time (**d2**) or temperature (**d3**), that is, defrosting will end when any one of the limit values of these parameters is reached.

F0 – Fan delay after draining: defines the time the fans will remain off after draining. This period allows the compressor to remove the heat from the evaporator after defrosting, preventing it from spreading inside the equipment.

F1 – Evaporator temperature to turn off the fans: if the evaporator temperature is above **F1**, the fans will be off.

F2 – Fan temperature differential (Hysteresis): if the fan turns off because the evaporator temperature has exceeded the value set in **F1**, it will only turn on again when the temperature is below “**F1 - F2**”. This parameter is used to prevent the fan from turning on and off too many times in a short period.

F3 – Cooling fan always on during refrigeration cycle: during the refrigeration cycle, if **F3 = YES**, the fan always remains on regardless of the status of the compressor relay. If **F3 = no**, the fan will only be on when the compressor is on.

F4 – Cooling fan always on during electric defrosting: with this parameter, you can keep the fan always on during electric defrosting.

P0 – Door open time to turn off the fan: this parameter defines the door open time to turn off the fan. If it is set to **Off**, the fan will not turn off when the door is opened.

P3 – Door sensor operating mode: defines the operating mode of the door sensor. If **P3 = nA** (normally opened), a closed contact represents the open door. If **P3 = nF** (normally closed), an open contact represents the open door.

P4 – Door closed time to enter eco mode: with this parameter, it is possible to force the system to enter eco mode when the door has not been opened for a specific period.

P5 – Door closed time to exit eco mode: the equipment will exit eco mode if the door remains closed for the time set in this parameter.

– Parameters available in full mode (Cd = 38) –

FE – Enable eco mode function: this parameter is used to block or unlock functions involving the system eco mode. **NOTE: if it is set to “no”, the system will never enter eco mode, regardless the value of the other parameters.**

FP – Power key function: parameter to control the function of the power key. The values and descriptions are listed below:

- **0** – key disabled;
- **1** – key will turn off/on the system standby mode;
- **2** – key activates/deactivates thermometer mode.

bt – Block of settings changes 10 s after the last use of the keyboard: in this parameter, the user can enable a lock for 10 seconds after the last use of keyboard, where:

- **off** – function disabled;
- **1** – Blocks all changes, except the setpoint;
- **2** – Blocks all changes.

Ed – Network address: this parameter defines the device address in standard RS-485 communication with the ISX10 (Arcsys). If the system has two or more controllers, they must not have the same **Ed** value.

bu – Block settings changes via WEB (ArcSys and Cloud): this parameter, when set to **YES**, prevents changes to controller parameters from being made via Arcsys/Cloud.

A0 – Temperature alarm differential (Hysteresis): this parameter defines the alarm temperature differential. In other words, how many degrees the temperature must be above the parameters **A1** or below **A2** so the alarm shuts off after activated.

A1 – Minimum temperature alarm: sets the lower alarm limit. If this limit is reached, the display will flash and the relay output will be switched off.

A2 – Maximum temperature alarm: sets the upper alarm limit. If this limit is reached, the display will flash and the relay output will be switched off.

A3 – Start-up alarm delay (refrigeration): defines the time the alarm monitoring will be deactivated after the beginning of the refrigeration cycle.

A4 – WEB notification frequency (ArcSys and Cloud): this parameter defines the frequency at which Arcsys/Cloud should send alert emails to the user, as long as the recipient's email is defined.

FL – Digital temperature filter: This parameter applies a filter to the temperature variation. The higher the filter value, the slower the temperature variation and the lower the filter value, the faster the variation. If the filter is at the maximum value (40), the temperature varies 0.1 °C every 2 seconds and, if it is at the lowest value (1), the temperature varies 0.1 °C every 0.05 seconds.

r4 – Refrigeration sensor calibration (offset): The value defined in this parameter applies an offset to the ambient temperature reading (refrigeration), for possible deviations in the sensor accuracy.

d9 – Defrosting sensor calibration (offset): The value defined in this parameter applies an offset to the evaporator temperature reading (defrost), for possible deviations in the sensor accuracy.

tl – Lowest temperature (historical minimum temperature): this parameter indicates the lowest temperature rec-

orded throughout the system's operation. **NOTE: This parameter is not adjustable, it is for viewing only (it can be redefined as wished).**

tH – Highest temperature (historical maximum temperature): this parameter indicates the highest temperature recorded throughout the system's operation. **NOTE: This parameter is not adjustable, it is for viewing only (it can be redefined as wished).**

Setting parameters

Follow the below steps to adjust the parameters, starting on the controller initial screen (when the ambient temperature is indicated):

a) Keep the **up** and **down** keys pushed simultaneously for 4 seconds. At the end of the 4 seconds, **Cd** will be shown on the display;

b) With the display showing **Cd**, keep the **set** key pushed and, using the **up** and **down** keys, increase the parameter value to **28** to allow the settings in simplified mode or **38** to full mode. Then, release the **set** key and **Cd** will be displayed again.

c) Using the **up** and **down** keys, navigate until you reach the parameter that needs to be modified. When the parameter to be changed is shown, keep the **set** key pushed and, using the **up** and **down** keys, change the values as desired. Release the **set** key so the value will be defined and you will go back to the parameters listing. The same can be done for the rest of the parameters;

d) After finishing all adjustments, keep the **up** and **down** keys pushed for 4 seconds to leave the parameters listing and return to the controller initial screen. **NOTE: Within 30 seconds, if no key is pushed, the controller will automatically leave the parameters listing.**

User access

✓ **Setpoint** – To change the system setpoint, push and hold the **set** key and adjust the value using the **up** and **down** keys (while still holding the **set** key). As soon as you reach the target setpoint, you can release the **set** key and the new setpoint will be defined. If you just want to view the setpoint value, just push and hold the **set** key. **NOTE: The eco mode setpoint will be displayed if the device is in eco mode; if the setpoint is changed on the initial screen, it will also be changed in the parameters listing.**

✓ **Skip to the next cycle** – To skip to the next cycle, press the **down** key for at least 4 seconds.

✓ **Defrost temperature sensor** – To check the temperature at the defrost sensor, press the **up** key.

✓ **Door sensor** – A normally open (NO) door sensor can be connected to the digital input.

✓ **Check controller status** – To check which state the controller is in (if it is refrigerating, defrosting, delaying, etc.) push the **down** key until the following indications are displayed:

- **CL** – Refrigerate – The system is in the refrigeration cycle.
- **dE** – Defrost – The system is in the defrosting cycle, indicated by the defrosting LED on;
- **Dr** – Drain – The system is in the draining cycle, indicated by the drain LED on. All of the relays will be off, waiting for the programed time, so it can change into the fan delay state;
- **Fd** – Fan delay – The system is in the fan delay state. The fan indication LED remains flashing during this state.

✓ **Standby mode** – If the **FP** parameter is set to **1**, push the power key to activate or deactivate Standby mode. In this mode, the controller switches off all relays and turns off the display, keeping only the power LED on.

✓ **Thermometer mode** – If the **FP** parameter is set to **2**, push the power key to activate or deactivate the thermometer mode. In this mode, the controller switches off all relays and keeps the temperature indication on the display.

✓ **Reset parameters to factory default** – To reset the controller to factory default settings, enter the value **97** to the **Cd** parameter and push the **A** key.

✓ **Alarm** – The user can set a temperature alarm so the display will flash to alert the user. The alarm is programmable by parameters **A0** to **A4**.

✓ **Testing the relays and door sensor** – Enter the parameters listing, change the **Cd** parameter to **77** and wait for **tst** to show up on the display. Push **A** button to test the defrost relay, **B** button to test the compressor relay and **Set** button to test the fan. The update symbol LED will be on if the door is open during test mode.

✓ **Programming key** – Another product that can be purchased separately is the programming key (FastKey). This device allows changing the controller parameters quickly and easily, as well as permit replicating the settings of a controller to other controllers.

✓ **Communication with Arcsys** – The controller has a USB input that can be connected to the ISX10, device for monitoring via the ArcSys interface. Have in mind that you will also need a RS-485 adapter to the wiring connection between the controller and ISX10.

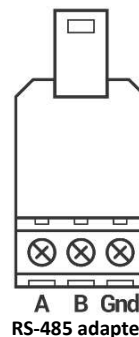

Connect the adapter to the controller USB output and attach to the iSX10. It is important to notice that the connection must be A-A, B-B and Gnd-Gnd.

Noise filter

When using the controller to manage inductive loads such as solenoid coils, contactors, motors or relays, it is recommended to install a noise filter circuit in parallel with the load terminals (A1 and A2), as described in the illustration below.

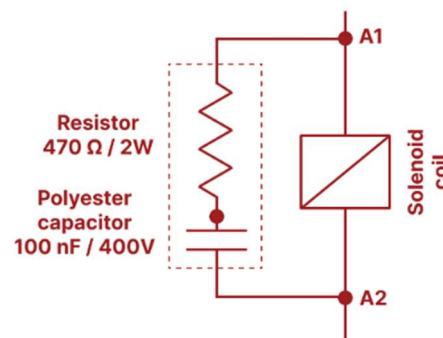

Automatic actions messages

The display has some messages to indicate automatic actions, as follows:

- **F1** – The value **F1** will be displayed for 1 second when the fans are turned off by maximum temperature protection;
- **d3** – The value **d3** will be displayed for 1 second when the defrost state is over by the maximum temperature protection perceived by the defrost sensor;
- **PA** – When the door is opened, the controller will end the eco mode and the display will indicate the value **PA**;
- **PF** – When the time entered in parameter **P4** is reached, the system automatically starts eco mode. In this situation, **PF** value will be displayed.

Error alerts

The **E1** error indication will appear on the device display whenever there is a problem with the ambient temperature sensor and **E2** for a problem with the evaporator temperature sensor. If any of that happens, check if:

- ✓ The sensor is well connected to the device;
- ✓ The sensor is within its temperature range;
- ✓ The sensor or its cable are damaged.

Package content

- ✓ 1 x A106 Temperature controller;
- ✓ 2 x NTC temperature sensor, 1.5 m long (wiring);
- ✓ 1 x A106 user guide.

Classification according to IEC 60730-2-9

Mounting surface temperature limit	Ts max 50°C
Storage conditions	(-20 to 70)°C; < 90% RH (noncondensing)
Operation frequency	Minimum T OFF between two starts must be greater than 1 min
Operation time limitation	@85°C – 2,000 h; @40°C – 100,000 h
Automatic action type	Type 1.C
Control pollution situation	2
Rated impulse voltage	1.5kV
Temperature for ball pressure test	(75 and 125)°C